

外形寸法図

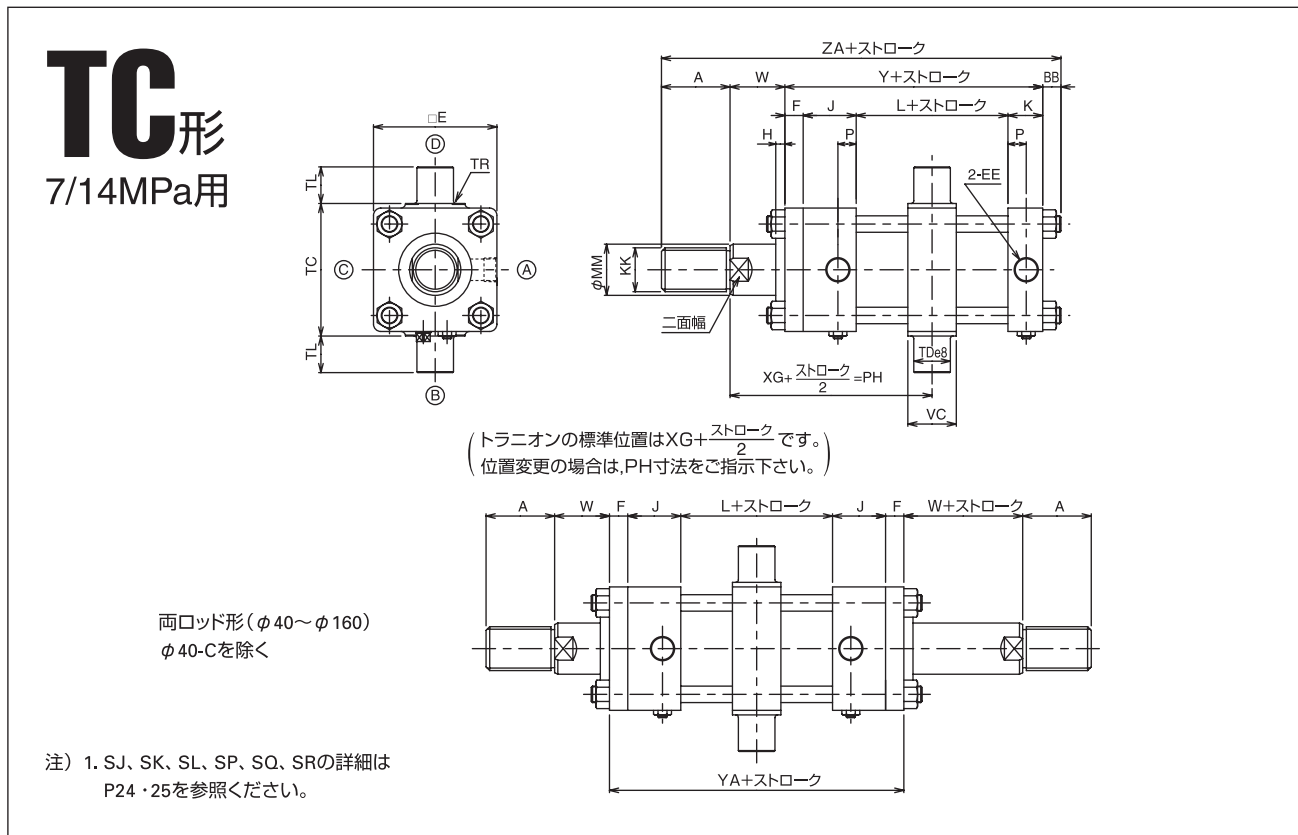

TC形基本寸法表

単位: mm

記号		シリンダ内径mm														
		30	40	50	63	80	100	125	140	150	160	180	200	224	250	
共 通	B系列ロッド (C系列ロッドは21頁を参照下さい)	A	25	30	35	45	60	75	95	110	115	120	140	150	180	195
		D	36	40	46	55	65	80	95	105	110	115	125	140	150	170
		H	10	10	10	10	10	10	10	10	10	10	10	10	10	10
		KK	M16 ×P1.5	M20 ×P1.5	M24 ×P1.5	M30 ×P1.5	M39 ×P1.5	M48 ×P1.5	M64 ×P2	M72 ×P2	M76 ×P2	M80 ×P2	M95 ×P2	M100 ×P2	M120 ×P2	M130 ×P2
		MM	18	22.4	28	35.5	45	56	71	80	85	90	100	112	125	140
		二面巾	14	19	24	30	41	50	65	75	80	85	95	105	115	130
		BB	10	11	11	13	16	18	21	22	25	25	27	29	34	37
		DD	M8	M10	M10	M12	M16	M18	M22	M24	M27	M27	M30	M33	M39	M42
		E	55	65	75	90	110	135	165	185	196	210	235	262	292	325
		EE(Rc)	3/8	3/8	1/2	1/2	3/4	3/4	1	1	1	1	1 1/4	1 1/2	1 1/2	2
		F	11	11	13	15	18	20	24	26	28	31	33	37	41	46
		J	42	42	46	48	58	58	68	68	68	69	85	95	95	115
		K	28	28	32	32	38	38	48	48	48	49	71	79	79	95
		L	60	60	64	68	70	76	80	88	96	104	86	90	90	90
		P	15	15	17	17	20	20	25	25	25	26	43	47	47	55
		W	30	30	30	35	35	40	45	50	50	55	55	55	60	65
	Y	141	141	155	163	184	192	220	230	240	253	275	301	305	346	
	クッションストローク	—	—	20	—	—	25	—	—	25	—	—	30	—	35	
	クッション アジャスタ	SJ	—	—	—	5	—	—	5	—	—	8	—	—	—	
		SK	—	—	—	17(M10)	—	—	17(M10)	—	—	26(M16)	—	—	—	
		SL	—	—	—	9	10	11	—	11	—	12	13	—	—	
	空気抜き	SP	—	7	—	9	12	—	12	—	14	17	19	—	—	
		SQ	—	2.5(M5)	—	3(M6)	4(M8)	—	4(M8)	—	—	5(M10)	—	—	—	
		SR	—	9(1/8)	—	10(1/4)	11(3/8)	—	11(3/8)	—	—	12(1/2)	13(3/4)	13(1)	—	
T C 形	TC	58 <sup>0</sup> <sub>-0.3</sub>	69 <sup>0</sup> <sub>-0.3</sub>	85 <sup>0</sup> <sub>-0.35</sub>	98 <sup>0</sup> <sub>-0.35</sub>	118 <sup>0</sup> <sub>-0.35</sub>	145 <sup>0</sup> <sub>-0.4</sub>	175 <sup>0</sup> <sub>-0.4</sub>	195 <sup>0</sup> <sub>-0.46</sub>	206 <sup>0</sup> <sub>-0.46</sub>	218 <sup>0</sup> <sub>-0.46</sub>	243 <sup>0</sup> <sub>-0.46</sub>	272 <sup>0</sup> <sub>-0.52</sub>	300 <sup>0</sup> <sub>-0.52</sub>	335 <sup>0</sup> <sub>-0.57</sub>	
	TD	20	20	25	31.5	31.5	40	50	63	63	71	80	90	100	100	
	TL	20	20	25	31.5	31.5	40	50	63	63	71	80	90	100	100	
	TR	2	2	2.5	2.5	2.5	3	3	4	4	4	4	5	5	5	
	VC	28	28	33	43	43	53	58	78	78	88	98	108	117	117	
	XG	113	113	121	132	146	156	177	188	194	207	216	232	241	271	
	YA	—	166	182	194	222	232	264	276	288	304	—	—	—	—	
	ZA	Bロッド	206	212	231	256	295	325	381	412	430	453	497	535	579	643
	Cロッド	—	207	226	246	280	310	361	382	400	—	—	—	—	—	